

**PTFE SELF LUBRICATED
BEARINGS**

Shaft Details

Shaft

Our shafts can be used in numerous application including with linear bearing for high accurate linear motion. The quality and accuracy of the shaft directly affect the performance of the linear bearing.



Material

High Carbon Bearing Steel: DIN 100Cr6

Quality Carbon Steel: DIN CK45

Stainless Steel: SUS440C

Chrome Plating if required

Hardness

All shafts are induction hardened for improved wear resistance. The Surface hardness is at least 58HRC.

Surface Roughness

All shafts are precision ground to a roughness less than Ra0.40

Shaft Machining Details

Customised machining requirements are available against OEM volume orders, please see below:

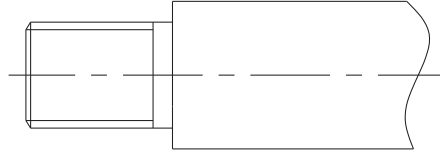

Screw

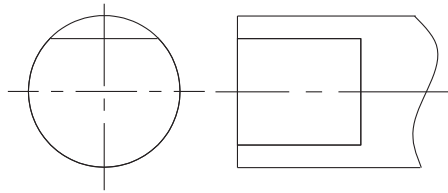

Plane

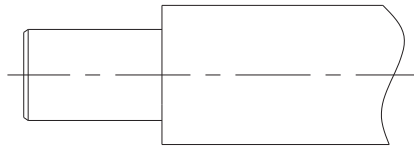

Ladder

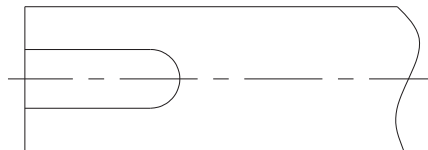

Keyway

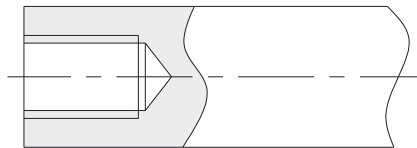

Screw hole

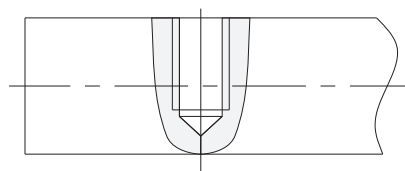

Screw hole

Shaft Sizing Details

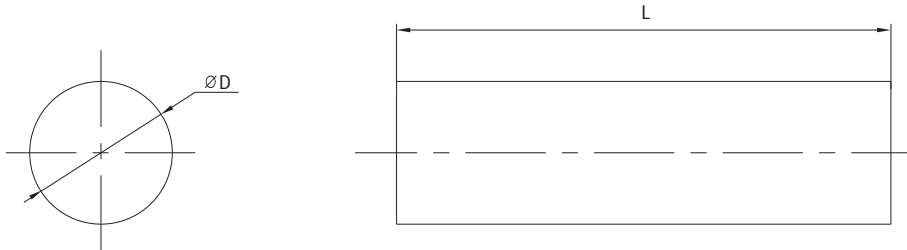

Outer Diameter		Max length	Weight Kg/m
D	Tolerance g6	L	
3*	-2/-8	— 300	0.06
4*	-4	— 500	0.10
5		— 1000	0.16
6	-12	— 3000	0.22
8	-5	— 4000	0.40
10	-14	— 4000	0.62
12	-6	— 4000	0.89
13*		— 4000	1.05
15*		— 4000	1.40
16		— 4000	1.59
20	-7	— 4000	2.48
25		— 4000	3.88
30		— 4000	5.58
35*	-9	— 4000	7.60
40		— 4000	9.92
50*		— 4000	15.50
60*	-10	— 4000	22.33
80*	-29	— 4000	39.69

*Non Stocked Item

Self-Lubricated Linear Bearings

The Saibo self-lubricate PTFE linear bearings' are used in a wide range of application and industries, such as medical equipment, food and package equipment, fitness equipment and precision punch machine.

Structure

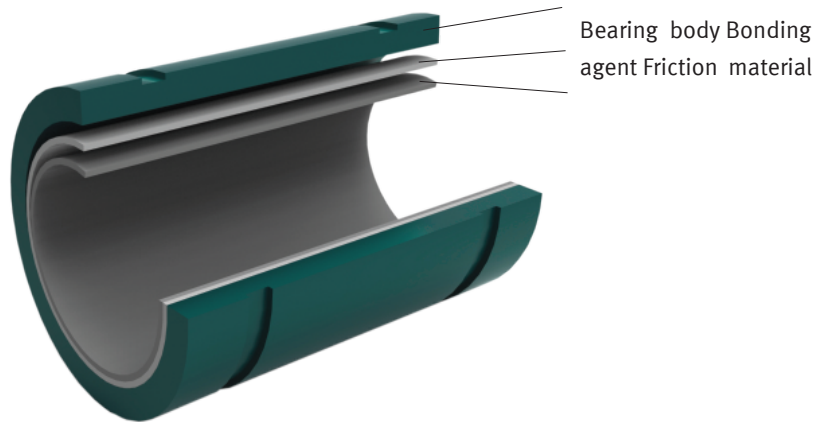

PTFE's excellent physical and chemical performance has been proven over several decades of applications. For a linear motion application

PTFE Bush Features:

PTFE's excellent physical and chemical performance have been approved after several decades' application requiring linear motion. The key advantages to using PTFE bushes are:

- Self-lubricate system
- Resist high and low temperature (-240°C ~ +260°C)
- Soft and can absorb vibration
- Anti-friction
- Good load capacity
- Excellent bonding performance with PTFE

PTFE Comparison Table

Below we have compared a PTFE bush to a Steel Ball Bearing Bush

	PTFE Self-lubricate linear bearing	Steel ball linear bearing
Load capacity	4-20 times load capacity than steel ball linear bearing	Fit for light load
Speed	Low and middle speed	Middle and high speed
Friction Coefficient	0.03-0.20	0.002-0.003
Noise	Quiet	Big noise
Lubrication	Without	Necessary
Anti-Corrosion	Good	None
Anti-vibration and shock	Good	None
Interchangeability	Good	Good
Running ways	Linear, Rotary or combination	Only linear
Acceptable shaft	harden or soft shaft	harden shaft
Machining	Hole can be machined	Can not

Pressure Velocity (PV) character

The Pressure Velocity (PV) factor is a key parameter during design and selection of a PTFE self-lubricate linear bearing. PV can define the friction performance between system's pressure and velocity. PTFE's mixture has an intrinsic limiting PV rating while the system running under certain conditions. Put simply, the more load applied to system, the slower it must move to avoid exceeding PV limit. The reverse is also true, more speed, less available load capacity. Overload and exceeding Max speed will cause frictional heat and accelerated wear.

Max PV value:	0.7 N/mm ² × m/s
Load capacity:	20 N/mm ² (MPa)
Max speed:	1.5m/s
Working temperature:	-50°C ~ +260°C
Friction Coefficient:	0.03~0.2

Below the table shows the PTFE self-lubricate linear bearing PV limit at 20°C working temperature.

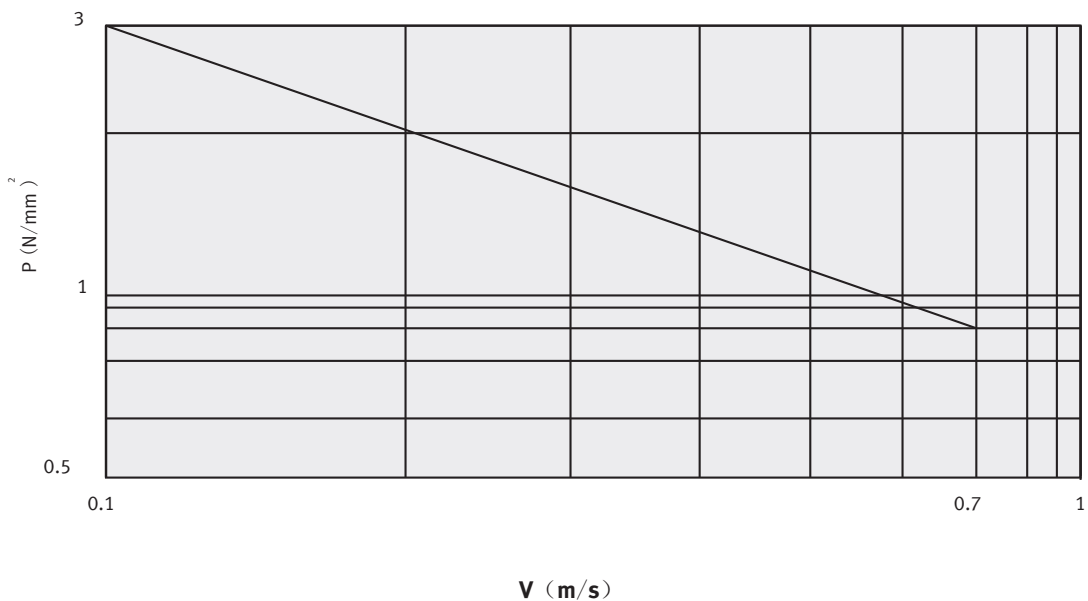

Maintenance and Mounting Shafts

Lubrication

PTFE and its mixtures have self-lubricate characteristics. Therefore, these bushes are an ideal linear solution in applications and environments where additional application of lubrication, is not possible or acceptable. However, if conditions permit, additional lubrication can reduce friction, by up to 30%. Which can extend the PTFE Bushes life considerably.

Recommended lubrication : Petroleum base oil or grease

Note: PTFE lubricates should NOT be use.

Recommend Mounting Shafts

To achieve the best rate of wear and performance from a PTFE self lubricating linear bearing, it is recommended that the following shaft parameters are used:

Surface roughness: Ra 0.4
Hardness: 55+HRC

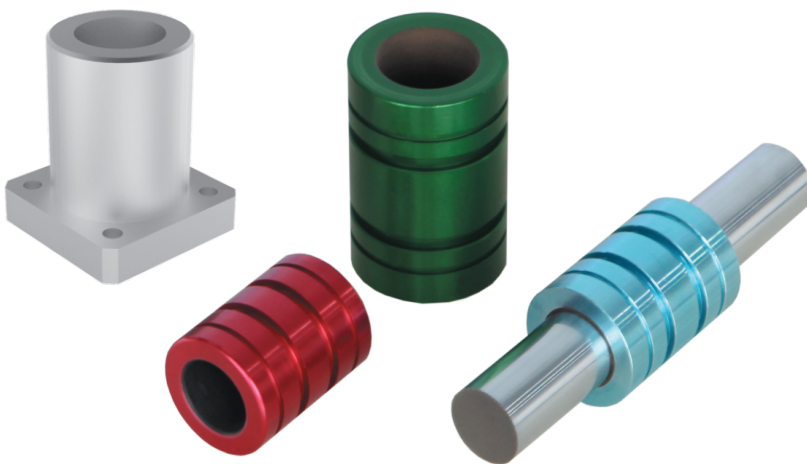

Standard type

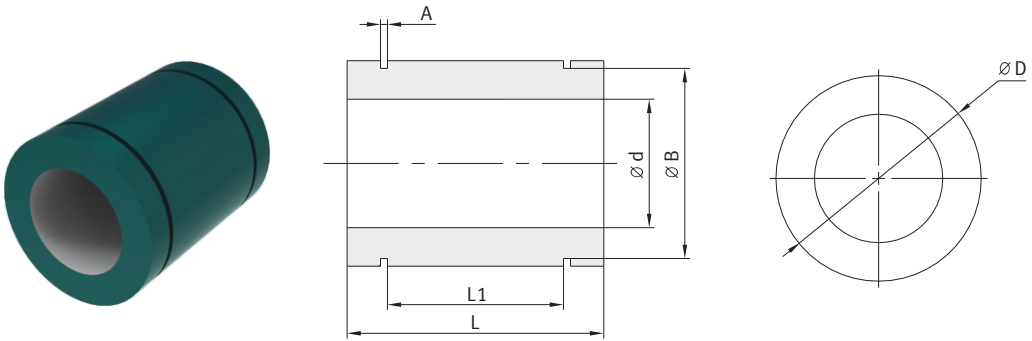

Type	Dimension						Load capacity (N)
	d	D	L	A	B	L1	
SLL06	6	12	19	1.15	11.50	11.30	2280
SLL08	8	15	24	1.15	14.30	15.20	3840
SLL10	10	19	29	1.35	18.00	19.30	5800
SLL12	12	21	30	1.35	20.00	20.30	7200
SLL13	13	23	32	1.35	22.00	20.30	8320
SLL16	16	28	37	1.65	26.60	23.20	11840
SLL20	20	32	42	1.65	30.30	27.20	16800
SLL25	25	40	59	1.85	38.00	37.20	29500
SLL30	30	45	64	1.85	42.50	40.70	38400
SLL35	35	52	70	2.20	49.00	44.80	49000
SLL38	38	57	76	2.20	54.50	54.30	57760
SLL40	40	60	80	2.20	57.00	56.10	64000
SLL50	50	80	100	2.70	76.50	68.60	100000
SLL60	60	90	110	3.15	86.50	78.70	132000
SLL80	80	120	140	4.15	116.00	97.20	224000
SLL100	100	150	175	4.15	145.00	117.20	350000
SLL120	120	180	200	4.15	175.00	150.30	480000
SLL150	150	210	240	5.15	204.00	160.30	720000

Square flange type

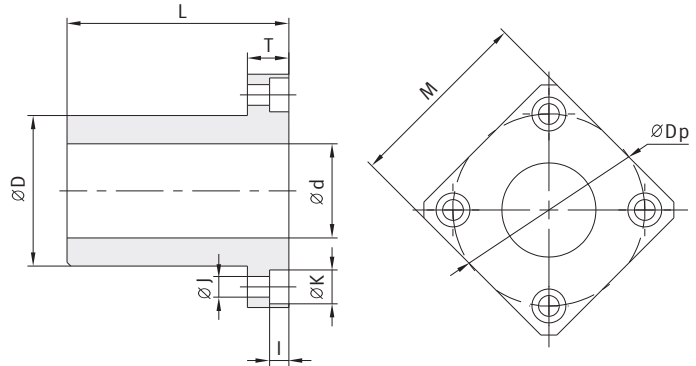
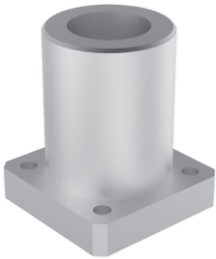

Type	Dimension									Load capacity (N)
	d	D	L	T	M	Dp	J	K	I	
SLL06 FN	6	12	19	8	22	20	3.50	6.00	3.10	2280
SLL08 FN	8	15	24	8	25	24	3.50	6.00	3.10	3840
SLL10 FN	10	19	29	9	30	29	4.50	7.50	4.10	5800
SLL12 FN	12	21	30	9	32	32	4.50	7.50	4.10	7200
SLL13 FN	13	23	32	9	34	33	4.50	7.50	4.10	8320
SLL16 FN	16	28	37	9	37	38	4.50	7.50	4.10	11840
SLL20 FN	20	32	42	11	42	43	5.50	9.00	5.10	16800
SLL25 FN	25	40	59	11	50	51	5.50	9.00	5.10	29500
SLL30 FN	30	45	64	14	58	60	6.60	11.00	6.10	38400
SLL35 FN	35	52	70	14	64	67	6.60	11.00	6.10	49000
SLL40 FN	40	60	80	18	75	78	9.00	14.00	8.10	64000
SLL50 FN	50	80	100	18	92	98	9.00	14.00	8.10	100000
SLL60 FN	60	90	110	24	106	112	11.00	17.00	11.10	132000
SLL80 FN	80	120	140	24	136	142	11.00	17.00	11.10	224000

SLIDING SYSTEMS

UNIT 9, GLEDRID INDUSTRIAL PARK, CHIRK,
WREXHAM, UK LL14 5DG
Tel: +44-1691-770-303
Fax: +44-1691-776-900

www.gsflides.com
info@gsflides.com

WUXI SAIBO INDUSTRY CO LIMITED

6-701 XIHU EAST ROAD, WUXI 214011, CHINA
Tel: +86-510-8230 0095
Fax: +86-510-8230 0096

www.saibo-bearing.com
info@saibo-bearing.com

